

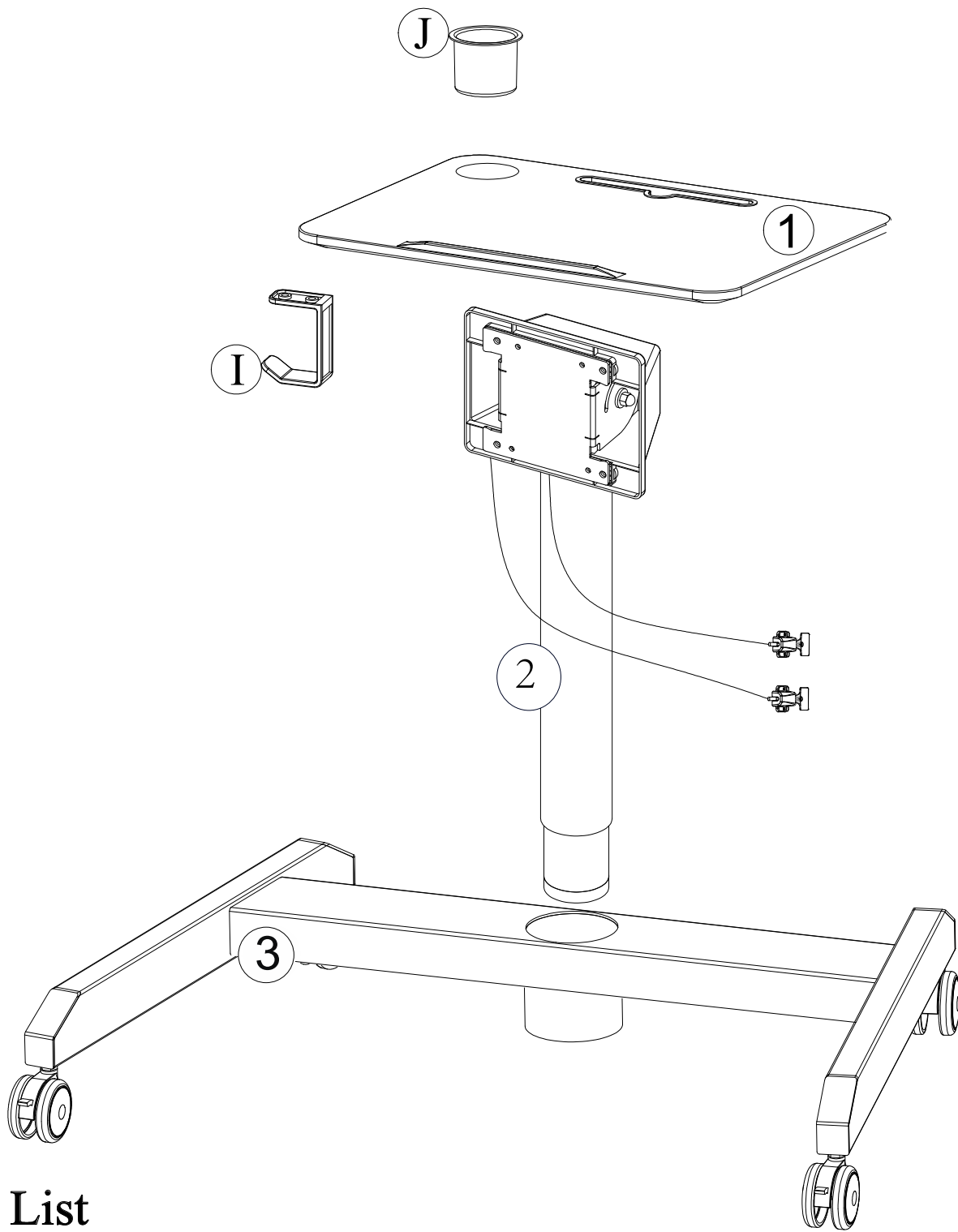



Warning:

1. The maximum static loading weight is 50 kgs and the dynamic loading weight is 4 - 6 kgs.
2. The desk cannot lift up by itself at the first time after placing sometimes or temperature is too low, you have to give a little pull force by hands to help lift up!
3. The desk has potential danger of tip-over if not used wisely, so children need to be accompanied by adult.

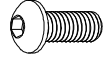
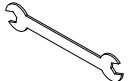
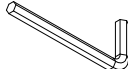

Parts List

	Ex3	M6x55 mm		Gx10	M6x16 mm
	Kx1			Hx1	4 mm
	Lx2			Mx2	

1

Fitting Instructions

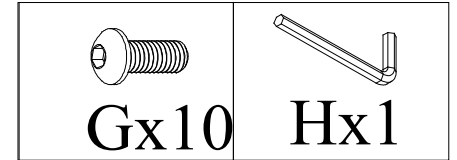
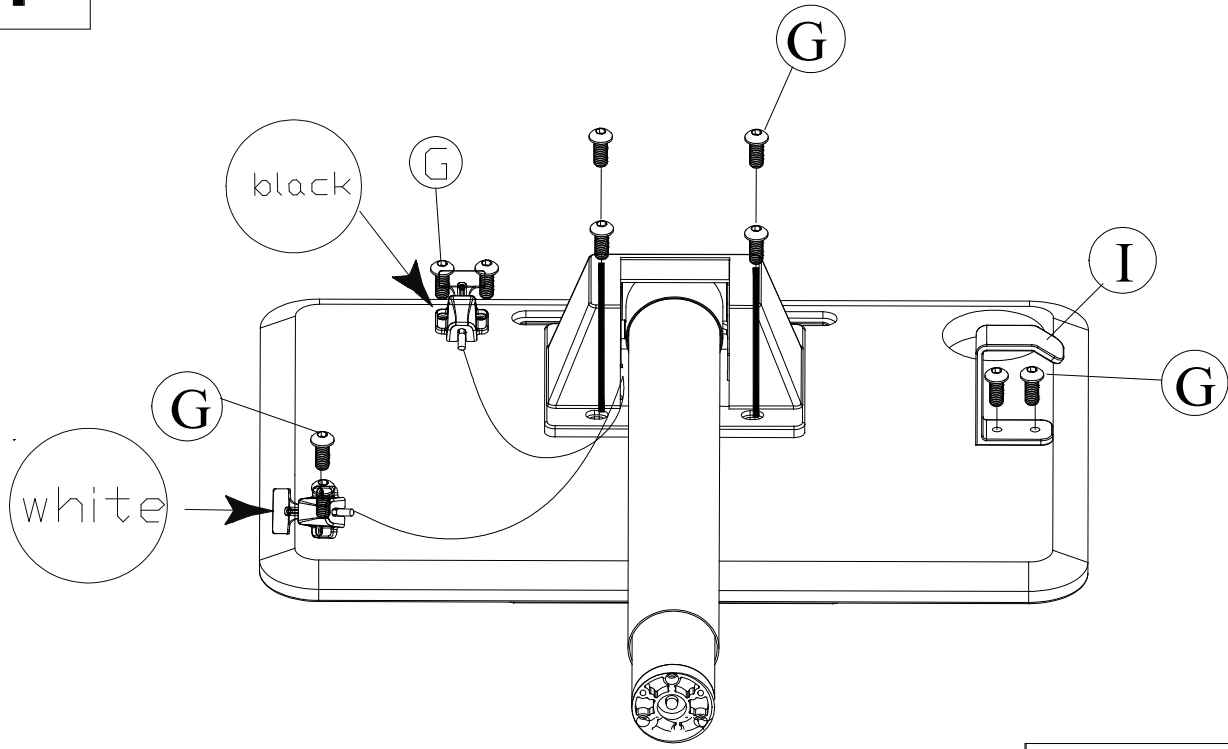

2

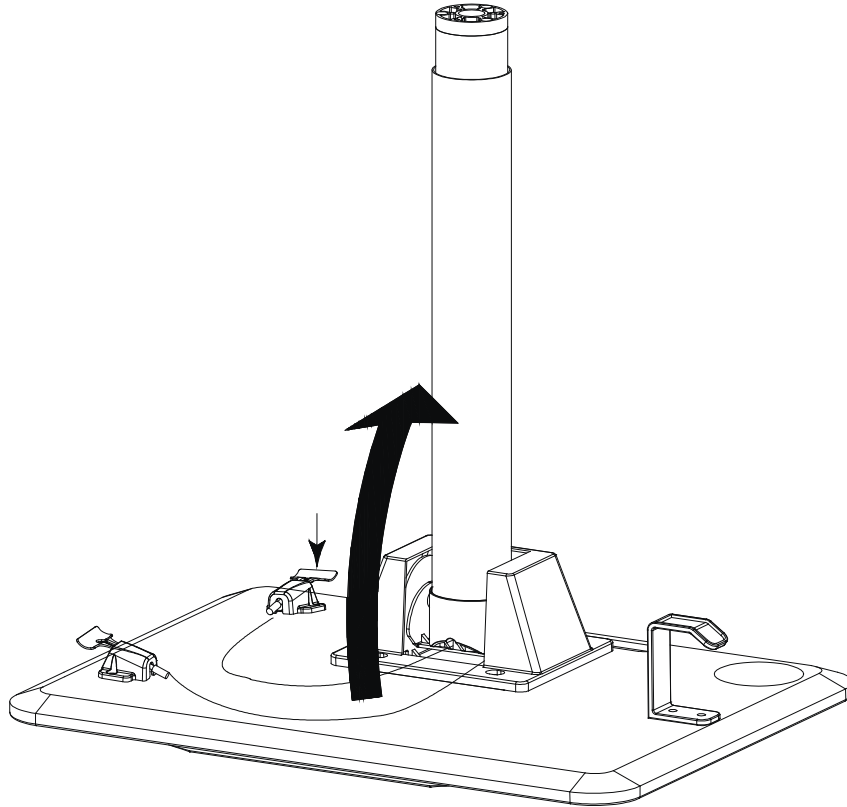

Turn up the switch and turn up 90° for the leg.

3

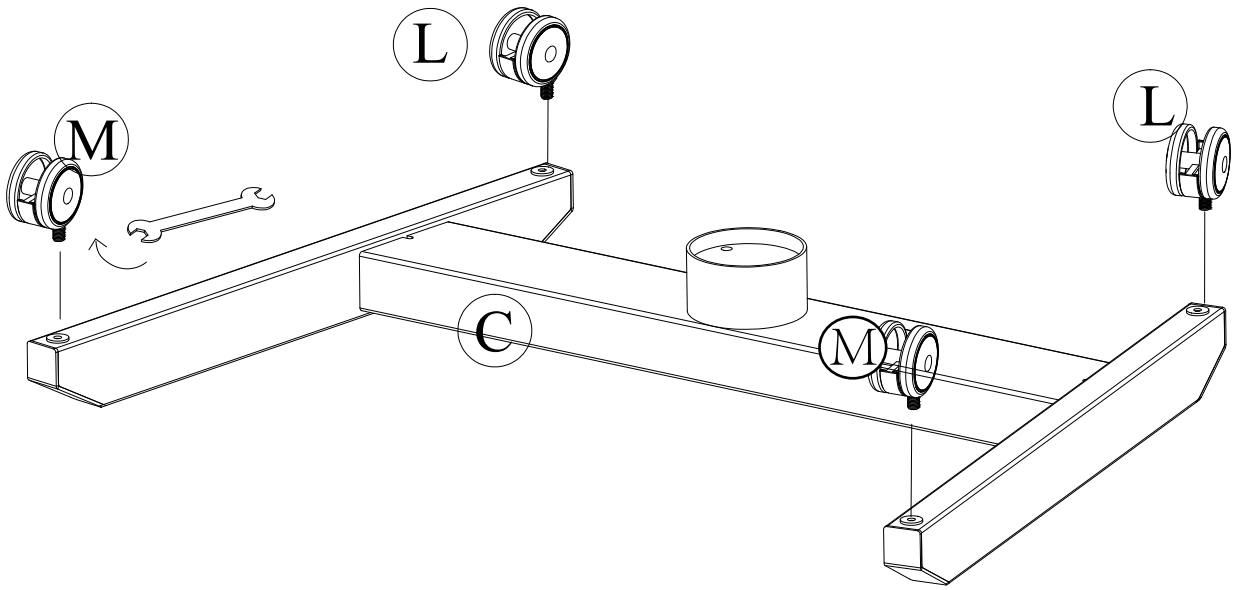

4

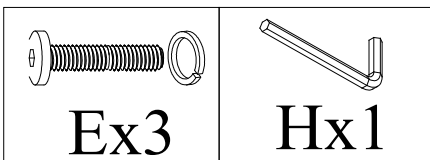
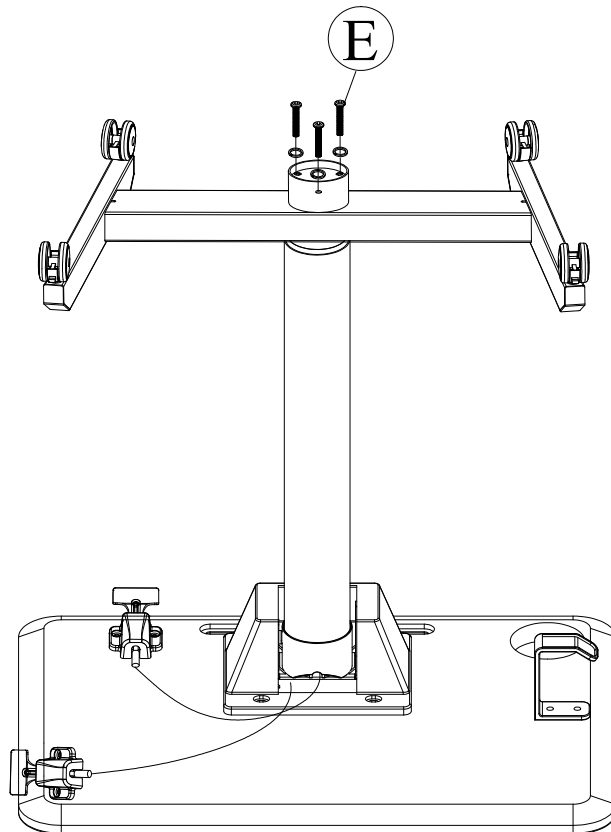

5

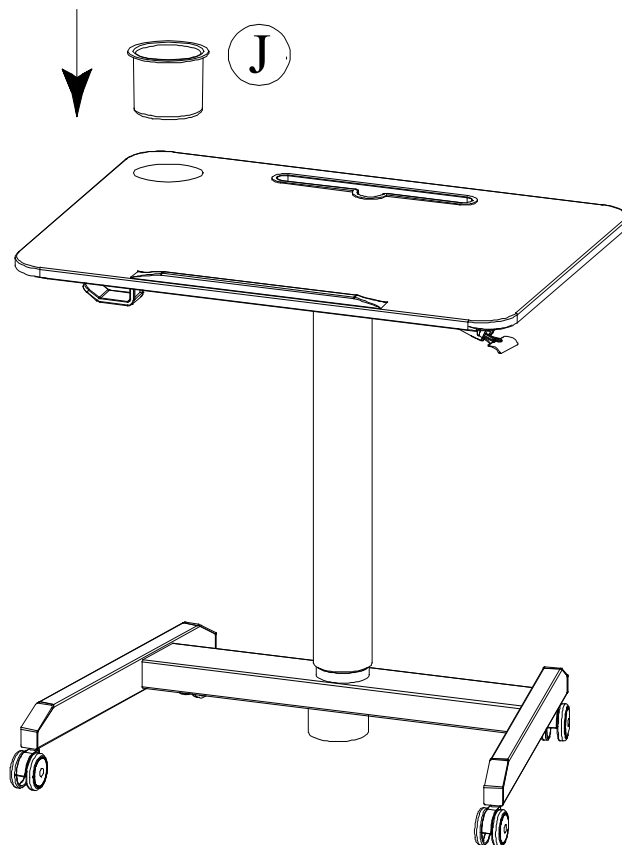

Operating Manual

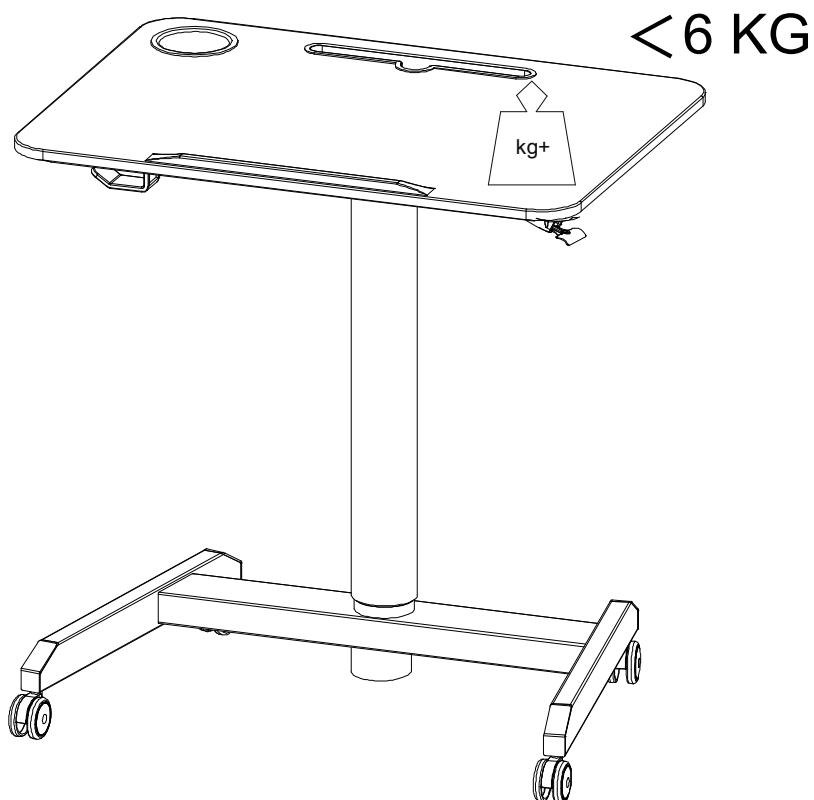

Attention : It is recommended not to exceed a maximum of 6 KG on desk top to allow for easy lifting

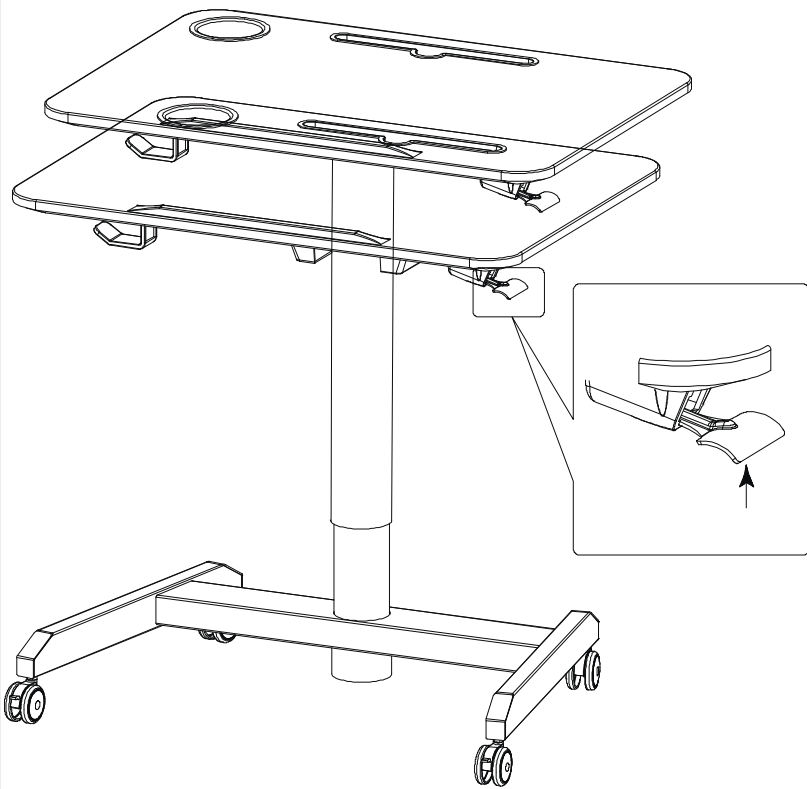

Lift the paddle for lifting the table top.

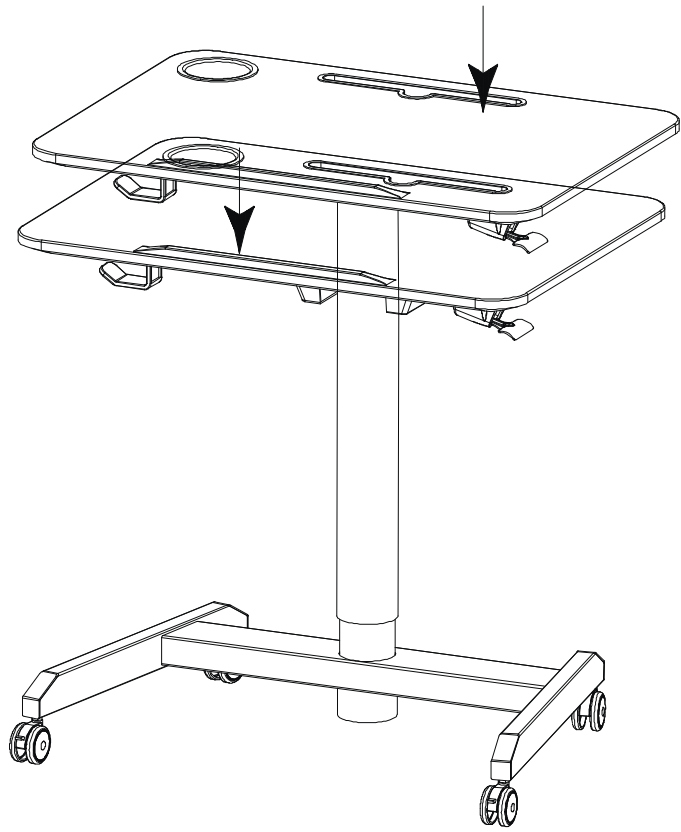

Lift the paddle and press the table top for downward operation.

Turn up the switch and turn up or down 90° for the table.

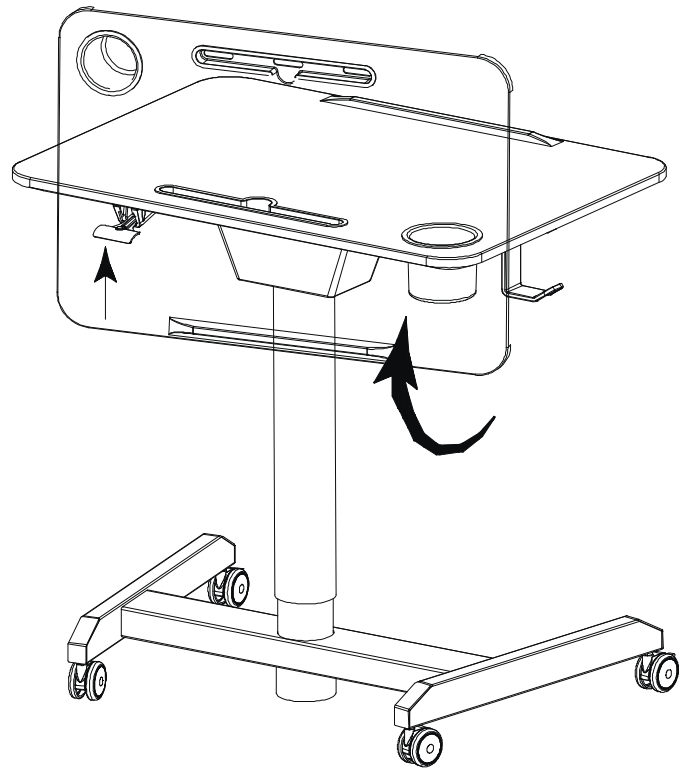
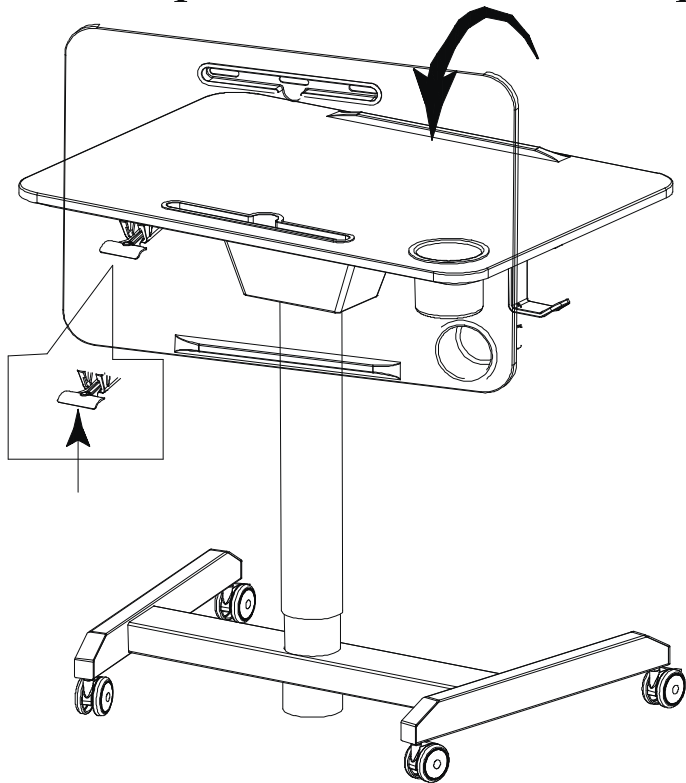

WARNING: There is a danger of falling objects on this table by turning the table up or down, so before turning over, make sure that there are no objects on the table and hold the table with both hands. Also children need to be accompanied by an adult.